

## 1. Features

- Green and Power Saving Available
- Equivalent Full Range Temperature Coefficient 30ppm/ °C
- Temperature-Compensated for Operation over Full Rated Operating
- Adjustable Hold on Current and Hold on Switch Timing
- No Output Noise
- Fast Turn-on Response
- RoHS Compliant, 100% Pb & Halogen Free



## 2. Description

PAB series control box is a small interface electronic device integrated into the DIN43650 Type A connector, improving the service life and performance of the solenoid valve. This product is designed with a power-saving circuit to reduce the coil temperature so that the valve can operate normally when opening and closing. PAB series power conversion circuits do not present any EMI issues. Additionally, an added a blinking LED indicator to notify that it has entered power-saving mode.(note1) The extent of power-saving or the time required to enter power-saving mode can be adjusted according to the customer's needs. For different coils and solenoid valves, PAB series can provide different power-saving effects and adjust parameters to accommodate customers' applications.

**Note1** : LED is darker while power saving mode active , LED is always bright in case of power saving mode suspend

## 3. Applications

- Solenoid Valve
- Valve Terminal
- Electric locks
- Switchgear



# Solenoid Valve Power Saving Control Box

Model: PAB Series

## 4. Technical Data

- 12/24VDC(-10%/+10%) Operating Vcc Range
- Pulse Output Current : 1200mA max.
- Continue Output Current : 400mA max. (Adj.)
- Power Saving Ratio : high to 80%(note1)
- Power Saving Covert Time 0~999mS Adj.(+/-10%)
- No EMI & Magnet Loss , Thermal Reduce
- No magnetic noise during operation
- Operating temperature -20C ~ 60C
- Module Model : PA Series

Note2 : depends on coil specification & solenoid on/off timing

Note3 : build in fuse on board to be safety issue upon surge power occur

## 5. Electrical Parameter Table

parameter		minimum	maximum	unit
Power Supply On	12V	10.8	13.2	V
	24V	21.6	26.4	
Maximum pulse current			1.2	A
Maximum cont. current			0.4(12V) , 0.2(24V)	A
Allowed coil resistance		full range		Ohm
pull in time		1	999	mS
holder power	1W	900	1100	mW
	1.5W	1350	1650	
	2W	1800	2200	
	2.5W	2250	2750	
ESD protection		4000		V
Module Operating Temperature(note2)		-20	60	°C
AI Main Chip Operation Temperature		-20	85	°C

Note2 . standard continuous holding power maxim time length is 4hrs.

Note3 . If your application is out of the specifications listed above. We can then customize the driver to meet your most demanding needs.

Note4. The driver closes automatically at voltages below the minimum operating voltage and eliminates the coil discharge voltage.

Note5. NOT be able to work by incorrect coil , example : 24V input but 12V coil/choke specification selected that is not working correctly.

## 6. Major Power Saving Function

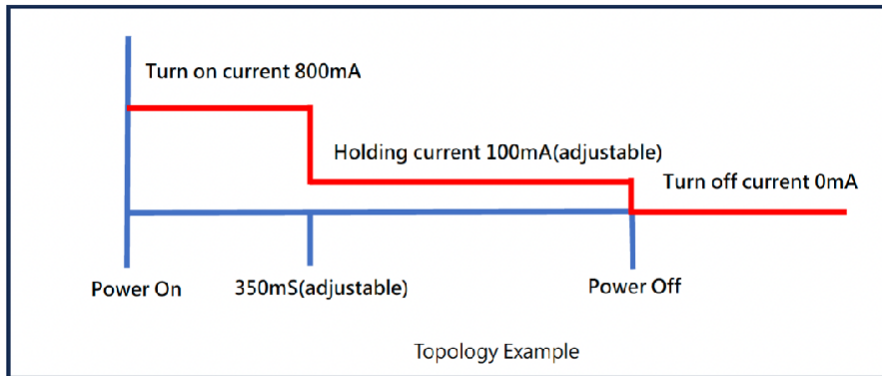

## 7. Major Circuit Diagram

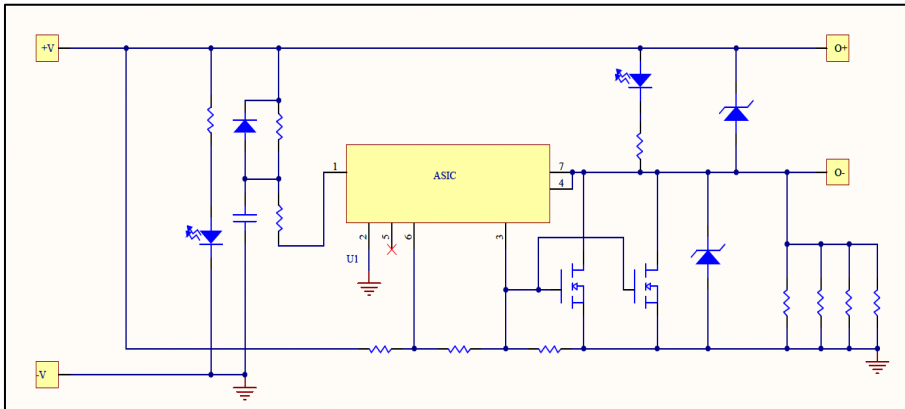

Surge Protection , LED x 2(power on & power saving indicated)

## 8. Control Box Spec & 3D

unit : mm (DIN43650A)

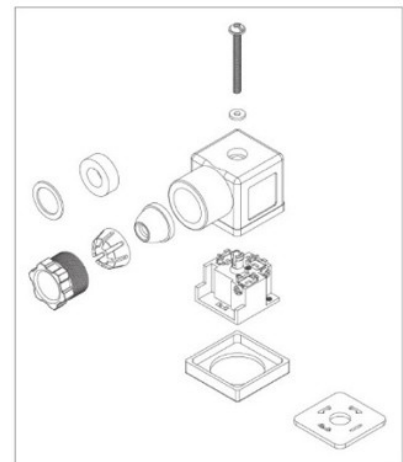
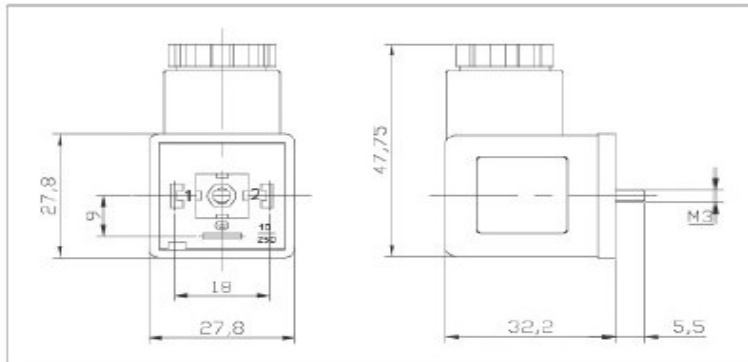



9. Ordering Information

**PAB-VV-WW-SS**

VV: Input Voltage range [unit:V]

VV value	12	24
Vcc min [ V ]	10.8	21.6
Vcc max [ V ]	13.2	26.4

WW: Holding power[unit:mW]

WW value	15	25	40
P hold [ mW ]	1500	2500	4000

SS: Translate Time (second stage time)[unit:ms]

SS value	20	35	50
Delay time	200ms	350ms	500ms



# Solenoid Valve Power Saving Control Box

Model: PAB Series

## Notice

Specifications of the products displayed herein are subject to change without notice. MIT or anyone on its behalf, assumes no responsibility or liability for any errors or inaccuracies.

Purchasers are solely responsible for the choice, selection, and use of MIT products and MIT assumes no liability for application assistance or the design of Purchasers' products.

Information contained herein is intended to provide a product description only. No license, express or implied, to any intellectual property rights is granted by this document. Except as provided in MIT's terms and conditions of sale for such products, MIT assumes no liability whatsoever, and disclaims any express or implied warranty, relating to sale and/or use of MIT products including liability or warranties relating to fitness for a particular purpose, merchantability, or infringement of any patent, copyright, or other intellectual property right.

The products shown herein are not designed for use in medical, life-saving, or life-sustaining applications. Customers using or selling these products for use in such applications do so at their own risk and agree to fully indemnify MIT for any damages resulting from such improper use or sale.

## Copy Rights and Disclaimer

This document may not be reproduced or duplicated, in any form, in whole or in part without prior written consent of MIT. Copyrights © 2023, MIT-Magnetic Integrated Technology Incorporated. MIT-Magnetic Integrated Technology reserves the right to make changes to the information published in this document at anytime without notice. MIT's products are limited for use in industrial and normal commercial applications. MIT's products are not to be used in any device or system, including but not limited to medical life support equipment and system.